

Vaisala Ground Check Device RI41 / RI41-B



Benefits

- Interface for wireless short range communication between Vaisala Radiosonde RS41 family and MW41 sounding software
- Interface is active – no short range transmitter in radiosonde
- Detects automatically the RS41 radiosonde and powers it up
- Fully compliant with ETSI EN 302 291-1 and -2
- The model RI41-B equipped with precise barometer module

Vaisala Ground Check Device RI41 – reliability with RS41 radiosonde.

The Ground Check Device RI41 is an essential tool for carrying out ground preparation of the Vaisala Radiosonde RS41. The RI41-B is similar to the RI41 but is equipped with a barometer module to provide an alternative to the ground check of the radiosonde's pressure measurement or surface pressure observation.

Both the RI41 and RI41-B are conveniently configured and operated with the Vaisala DigiCORA® Sounding System MW41.

RS41 Ground Check with RI41 and RI41-B

The Vaisala Radiosonde RS41 temperature sensor utilizes linear resistive platinum technology and is very stable. The humidity sensor combines humidity and temperature sensing elements to provide consistent results in all sounding conditions. The optional pressure

sensor is a high-quality, shock-resistant capacitive silicon sensor. All RS41 sensors are calibrated against references that are traceable to international standards (SI units).

The MW41 sounding system detects and automatically powers up the RS41 radiosonde when it is placed onto the ground check device.

Radiosonde preparation involves several steps, including sensor functionality checks and setting the desired options for in-flight operational parameters, like timer to power off the radiosonde at the desired time, pressure, or altitude. During the preparation procedure the operator can also set the transmitter frequency of the radiosonde or apply the station default frequency.

A ground check of the RS41 temperature sensor includes several advanced electrical checks and a comparison against the temperature element of the humidity sensor.

For the RS41 temperature sensor only comparison is made, meaning no corrections to radiosonde measurement are applied. Due to the lack of environmental control, the acceptance limits for the comparison are set accordingly.

The unique design of the sensors in the RS41 enables automatic reconditioning and physical zero humidity check of the humidity sensor during ground preparations. Prior to flight, reconditioning effectively removes chemical contaminants that could affect the humidity measurement. The physical zero humidity check is based on generating dry conditions by heating the humidity sensor. This result in dry reference corrections that are more reliable than those made using drying desiccants with limited drying capacity.

For the pressure measurement ground check, the MW41 sounding software compares the RS41's pressure sensor reading with that of the RI41-B's highly accurate, built-in barometer module and adjusts the measurement accordingly. The other alternative is to use an external precision barometer for the comparison and input the barometer's pressure value into the MW41 sounding software manually.

In addition to use during ground preparations, the pressure measurement from the barometer module can be used as a surface pressure value when the MW41 station parameters are set accordingly.

Wireless Short-Range Communication Link

The RI41/RI41-B uses a wireless short-range data link for communication between the RS41 and MW41. The link uses RF technology and has a range of 4 cm. During ground preparations, only the RI41/RI41-B device is active, and there is no short-range transmitter on the radiosonde.

The communication link operates at 13.56 MHz and is fully compliant with the ETSI EN 302 291-1 and -2 standard.

Technical Data

Operational Data

Short range wireless communication	RF technique
Frequency (carrier)	13.56 MHz
Transmitting power	200 mW max.
Communication link range	0.04 m
Electrical interface	USB 1.1/2.0
Cable with connector	USB
Cable length	1.8 m
Operating temperature range	+10 ... +35 °C
Operating humidity range	10 ... +95 %RH

Power Supply

Input	via USB interface
Voltage	5 VDC
Typical current	300 mA

Storage

Storage temperature range	-40 ... +65 °C
Storage humidity	5 ... +95 %RH

General

Material	Polyurethane
Weight	1.1 kg
Dimensions (W x L x H)	125 x 327 x 63 mm

Reference Sensors

Pressure, in the RI41-B model only	
Calibration of the module	Class A, NIST traceable
Uncertainty ¹⁾	0.15 hPa
Long term stability	0.1 hPa/year

¹⁾The recommended in-field calibration interval for barometer module is one year

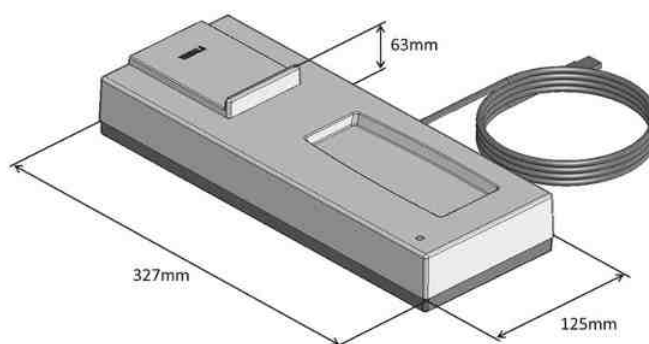

VAISALA

www.vaisala.com

Please contact us at
www.vaisala.com/requestinfo



Scan the code for more information

Ref. B211322EN-B ©Vaisala 2014

This material is subject to copyright protection, with all copyrights retained by Vaisala and its individual partners. All rights reserved. Any logos and/or product names are trademarks of Vaisala or its individual partners. The reproduction, transfer, distribution or storage of information contained in this brochure in any form without the prior written consent of Vaisala is strictly prohibited. All specifications — technical included — are subject to change without notice.

